

Modular distribution and connection boxes

● Distribution boxes - IP 55

These boxes are supplied complete with screws and gaskets for the cover, screw caps and fair-leads for knock-outs.

Inlets to be knocked out version

Description	Inlets to be knocked out	Part number
90×180×85 mm	8×Pg 21	EECB90×180×85 - 8

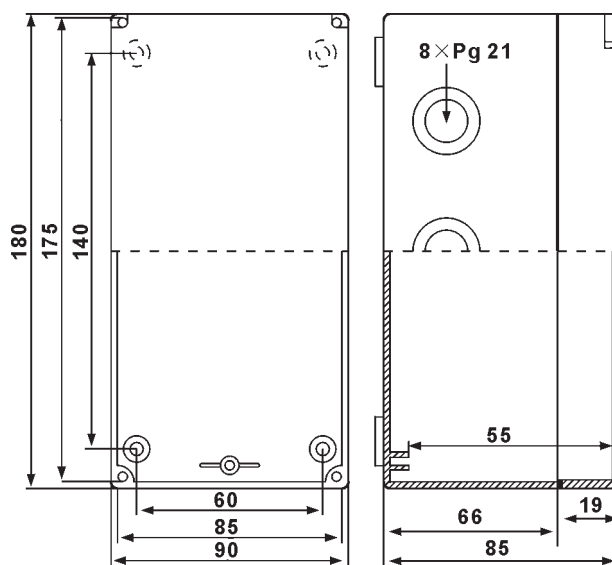

Unmarked walls version

Description	Part number
90×180×85 mm	EECB90×180×85 - 0

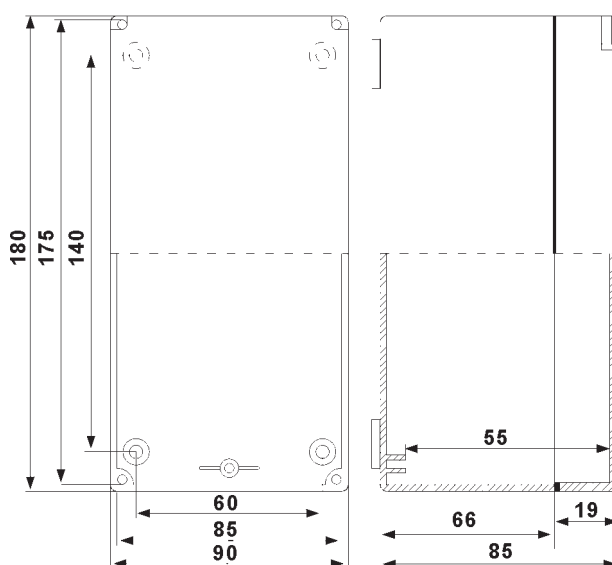

● Distribution boxes - IP 55

Technical data

Characteristic	PC	ABS	Used for standard (UL CSA CE)
Protection class (En60529)	IP55	IP55	American : used for electric equipment boxes PC:UL style 1 4 4X 6(12 and 13) (UL 50/508) ABS :NEMA 1 4 4X 6(12 and 13)
Resist striking (En5012)	IK 08	IK 07	Canada : Industry control equipment used for electric equipment /ULc
Temperature ranges (Temporary) F	-40 -120	-40 -80	Europe: Used for components of the switch box and control box
Temperature ranges (Continuous) F	-40 F -250 F	-40 F -175 F	EN 50298 1998
Temperature ranges (Continuous) F	-40 -80	-40 -60	Europe : Used for the security of IT equipment
Temperature ranges (Continuous) F	-40 F-175 F	-40 F-140 F	EN 60950
The electric insulation	Completely insulating	Completely insulating	Australia : Used for switch box and control box
Light grey part colour	RAL 7035 Industry grey	RAL 7035 Industry grey	AS 3132 - 1991
Cover colour	Transparence	grey	
Screw for the cover	Silvery white	Silvery white	
Screw for the sheet	Light yellow	Light yellow	
Gasket	PUR/TPE	PUR/TPE	
Flammability class	UL 94 -5V	UL 94HB	UL 746 C 5 inch perpendicularity flame test
Burning conductor test	960	650	IEC 695 - 2 - 1 self-extinguishing
Innocuous properties	No halogen	No halogen	
Preventing ultraviolet radiation	UL 508		
Resist chemical corrosion	Be in aging machine 720 hours still well	Well	